

二段水切一覧

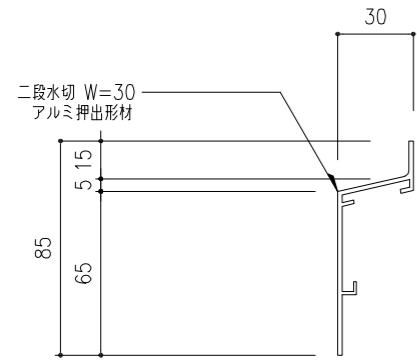

W=30

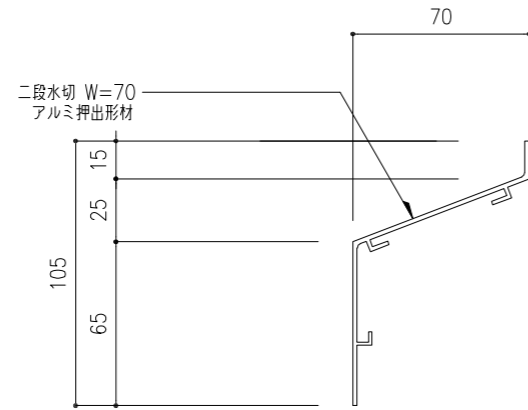

W=70

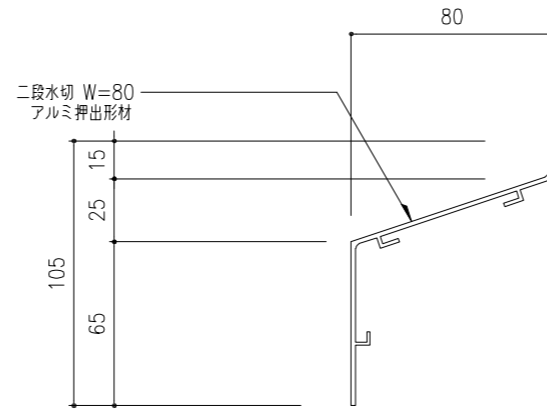

W=80

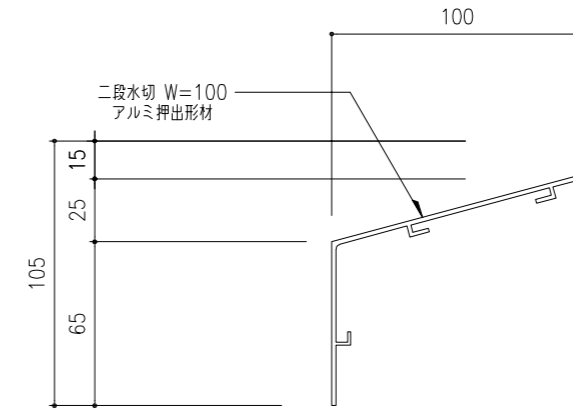

W=100

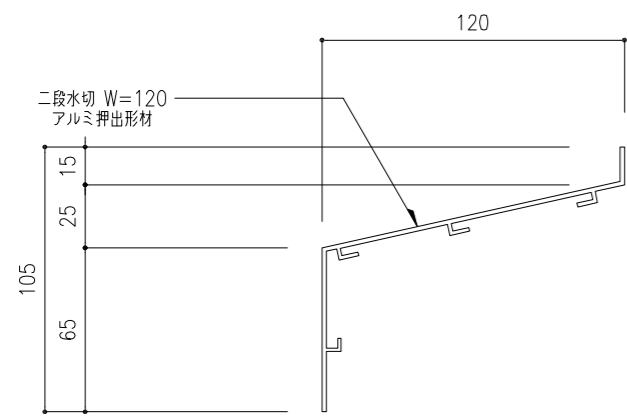

W=120

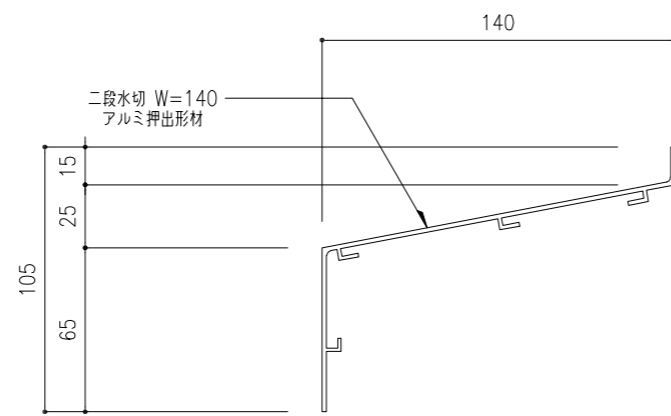

W=140

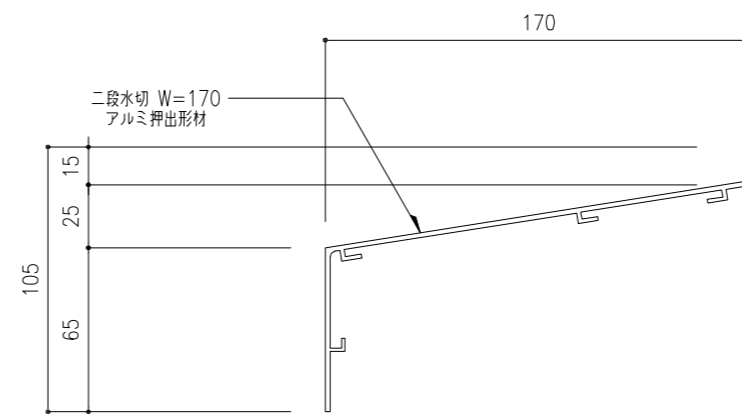

W=170

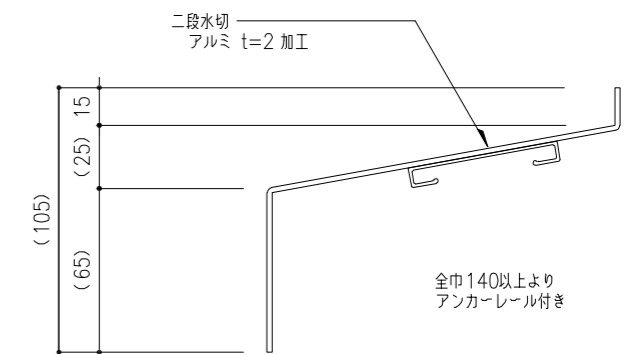

曲げ

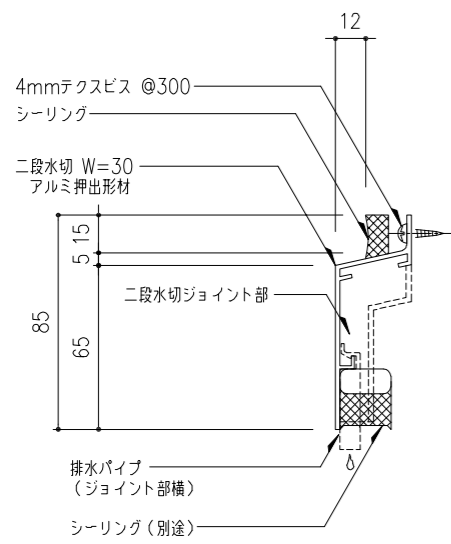

W=30

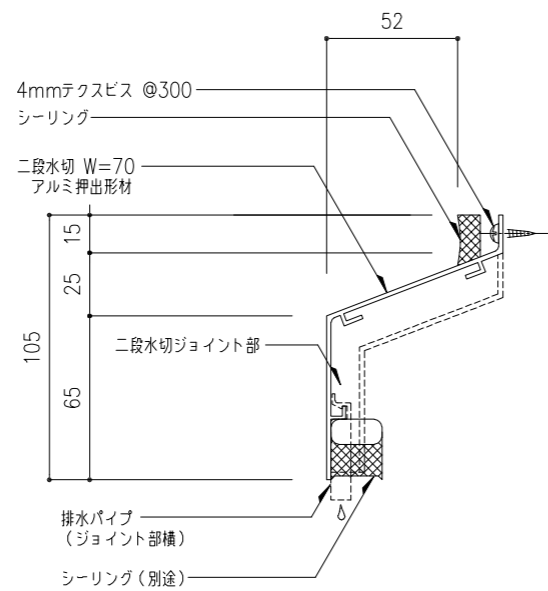

W=70

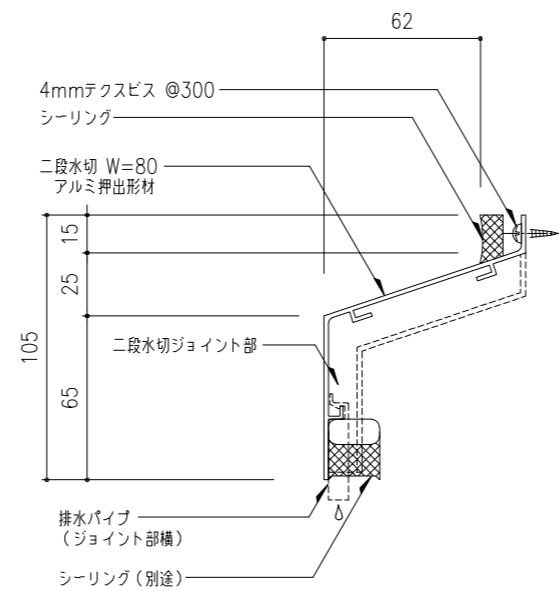

W=80

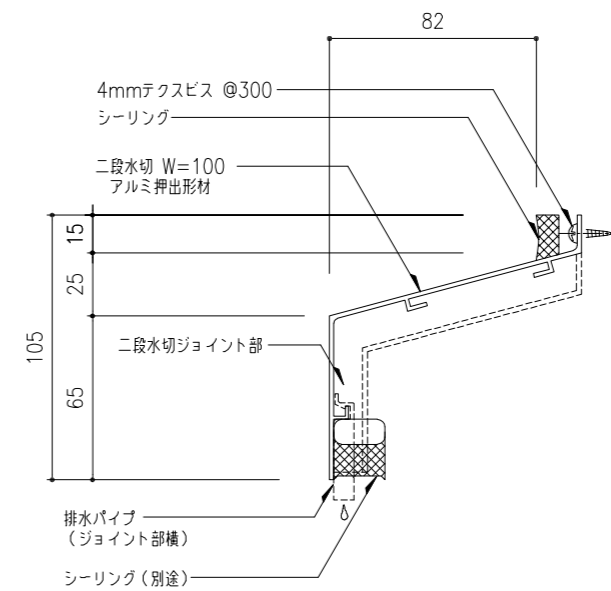

W=100

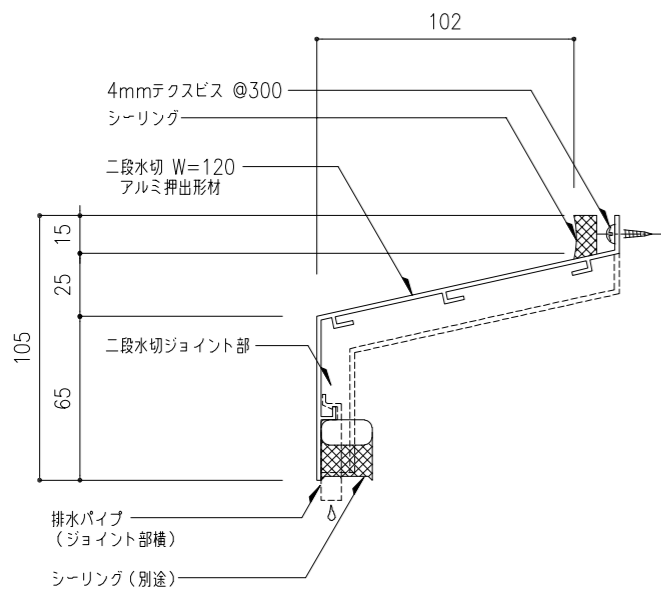

W=120

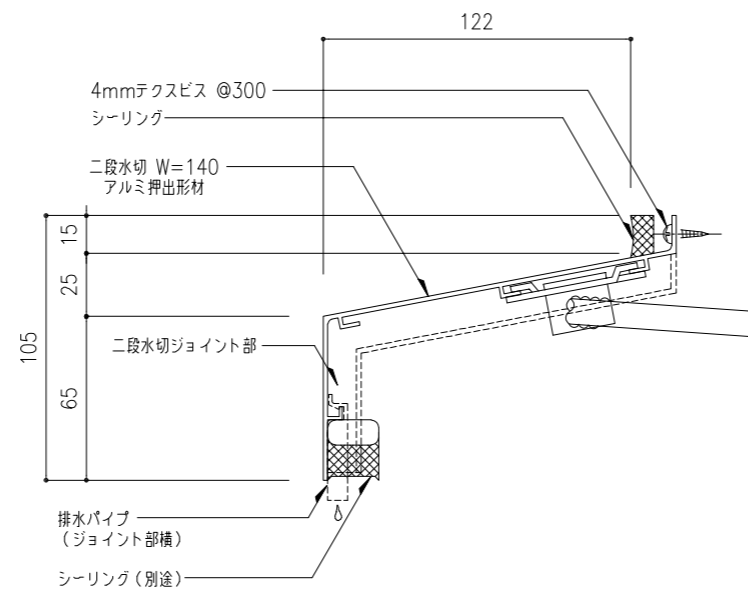

W=140

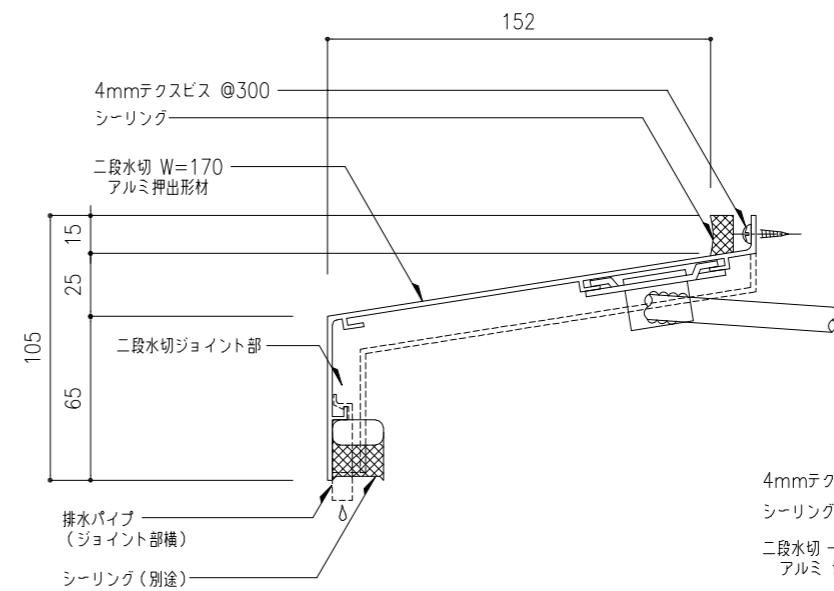

W=170

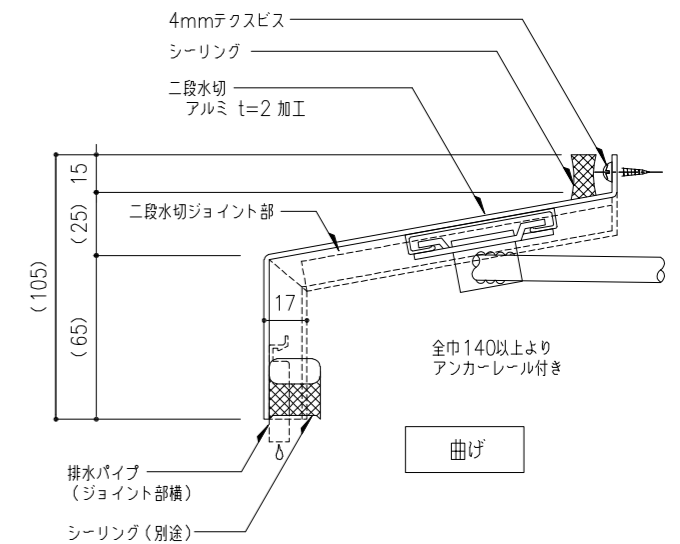

曲げ